

ES

**Feature: Miniaturized, Low E.S.R. and impedance.
Capacitors for use in high ripple current capability.**

SPECIFICATIONS

Item	Performance Characteristics																		
Category Temperature Range	-40 to +105°C																		
Working Voltage Range	6.3 to 100Vdc																		
Capacitance Range	4.7 to 10,000 μ F																		
Capacitance Tolerance	$\pm 20\%$ (at 25°C 120Hz)																		
Dissipation Factor ($\tan \delta$) (at 25°C 120Hz)	<table border="1"> <thead> <tr> <th>Rated Voltage (V)</th> <th>6.3</th> <th>10</th> <th>16</th> <th>25</th> <th>35</th> <th>50</th> <th>63</th> <th>100</th> </tr> </thead> <tbody> <tr> <td>$\tan \delta$ (Max)</td> <td>0.15</td> <td>0.14</td> <td>0.12</td> <td>0.10</td> <td>0.10</td> <td>0.08</td> <td>0.08</td> <td>0.07</td> </tr> </tbody> </table> <p>The above values should be increased by 0.02 for every additional 1000 μ F</p>	Rated Voltage (V)	6.3	10	16	25	35	50	63	100	$\tan \delta$ (Max)	0.15	0.14	0.12	0.10	0.10	0.08	0.08	0.07
Rated Voltage (V)	6.3	10	16	25	35	50	63	100											
$\tan \delta$ (Max)	0.15	0.14	0.12	0.10	0.10	0.08	0.08	0.07											
Leakage Current	$I=0.01CV$ or 3μ A, whichever is greater I: Leakage current. (μ A) C: Rated capacitance. (μ F) V: Rated voltage. (V) The rated voltage is impressed for two minutes.																		
Endurance	After applying rated voltage to the capacitor for 2,000 hours at 105°C, the following characteristics shall be satisfied when the capacitor has been restored to 25°C. Capacitance change $\cong \pm 20\%$ of the initial value Dissipation factor ($\tan \delta$) $\cong 200\%$ of the specified value Leakage current \cong specified value																		
Shelf Life	After exposing the capacitor for 500 hours at 105°C, without applying voltage, the following characteristics shall be satisfied when the capacitor has been restored to 25°C. Capacitance change $\cong \pm 20\%$ of the initial value Dissipation factor ($\tan \delta$) $\cong 200\%$ of the specified value Leakage current $\cong 200\%$ of the specified value																		
Others	Conforms to JIS C-5141 (1991), characteristic W																		

RIPPLE CURRENT MULTIPLIERS

Temperature Multipliers

Temp (°C)	40	60	70	85	95	105
Factor	2.10	1.90	1.65	1.40	1.25	1.00

Frequency Multipliers

Vdc	Freq.(Hz)					
	Cap.(μ F)	50(60)	120	1K	10K	100K
6.3 to 100	4.7 to 68	-----	0.17	0.65	0.85	1.00
	82 to 220	0.30	0.50	0.80	0.90	1.00
	330 to 820	0.57	0.71	0.90	0.95	1.00
	1000 to 10000	0.75	0.87	0.98	1.00	1.00

DIMENSIONS(mm)

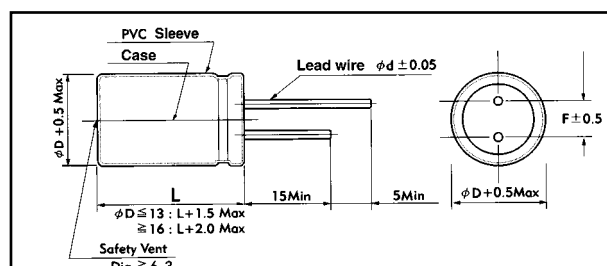

ϕD	5	6.3	8	10	13	16	18
ϕd	0.5	0.5	0.6	0.6	0.6	0.8	0.8
F	2.0	2.5	3.5	5.0	5.0	7.5	7.5

ES

Case size & Permissible Ripple Current

Nominal Capacitance (μ F)	6.3 V			10 V			16 V		
	Case Size	Max. Impedance @25°C 100kHz (Ω)	Max. Ripple Current @105°C 100kHz (mA rms)	Case Size	Max. Impedance @25°C 100kHz (Ω)	Max. Ripple Current @105°C 100kHz (mA rms)	Case Size	Max. Impedance @25°C 100kHz (Ω)	Max. Ripple Current @105°C 100kHz (mA rms)
	ϕ DxL (mm)			ϕ DxL (mm)			ϕ DxL (mm)		
100	5x11	1.780	120	5x11	1.480	155	6.3x11	1.280	200
220	6.3x11	0.880	252	6.3x11	0.580	300	8x12	0.460	550
330	6.3x11	0.450	280	8x12	0.380	550	8x12	0.280	580
470	8x12	0.140	550	8x12	0.140	600	8x16	0.090	730
560	8x12	0.130	580	8x16	0.120	700	8x20	0.080	810
680	8x12	0.120	600	8x16	0.110	730	10x16	0.064	1050
820	8x16	0.090	730	8x20	0.080	1000	10x20	0.044	1100
1000	8x16	0.085	780	8x20	0.065	1080	10x20	0.039	1250
1000	10x12	0.084	785	10x16	0.064	1055	10x25	0.039	1280
1200	8x16	0.085	790	10x20	0.044	1250	10x25	0.038	1450
1500	8x20	0.080	810	10x20	0.039	1450	10x30	0.034	1600
1500	10x16	0.055	1060	10x25	0.038	1460	13x20	0.034	1600
2200	10x20	0.043	1250	10x20	0.038	1460	13x25	0.028	2000
2700	10x25	0.039	1600	13x20	0.037	1650	13x30	0.028	2100
3300	13x20	0.038	1660	13x25	0.028	2000	13x35	0.024	2220
3900	13x20	0.037	1670	13x25	0.027	2060	13x40	0.023	2350
4700	13x25	0.033	1700	13x30	0.024	2200	16x32	0.019	2550
5600	13x30	0.029	1750	13x35	0.023	2300	16x36	0.019	2680
6800	13x35	0.024	2000	16x32	0.019	2550	16x40	0.019	2800
8200	16x32	0.019	2350	16x36	0.019	2800	18x36	0.018	3000
10000	16x36	0.019	2550	16x40	0.018	3000	18x40	0.017	3150

Nominal Capacitance (μ F)	25 V			35 V			50 V		
	Case Size	Max. Impedance @25°C 100kHz (Ω)	Max. Ripple Current @105°C 100kHz (mA rms)	Case Size	Max. Impedance @25°C 100kHz (Ω)	Max. Ripple Current @105°C 100kHz (mA rms)	Case Size	Max. Impedance @25°C 100kHz (Ω)	Max. Ripple Current @105°C 100kHz (mA rms)
	ϕ DxL (mm)			ϕ DxL (mm)			ϕ DxL (mm)		
47	5x11	0.880	150	6.3x11	0.760	250	6.3x11	0.640	300
68	6.3x11	0.660	200	8x12	0.560	300	8x12	0.480	450
100	6.3x11	0.430	250	8x12	0.380	450	8x16	0.220	550
150	8x12	0.140	500	8x12	0.120	555	8x20	0.180	780
220	8x12	0.120	730	8x16	0.100	600	10x16	0.100	1050
330	8x16	0.090	750	10x20	0.068	1050	10x20	0.072	1300
470	10x16	0.064	1050	10x20	0.046	1300	13x20	0.060	1400
560	10x20	0.065	1100	10x25	0.039	1350	13x25	0.058	1480
680	10x20	0.039	1110	10x30	0.038	1400	13x25	0.050	1550
820	10x20	0.039	1250	13x20	0.034	1550	13x35	0.040	1700
1000	13x20	0.038	1450	13x25	0.029	1700	13x35	0.039	1900
1200	13x25	0.033	1600	13x30	0.028	1900	16x32	0.025	2100
1500	13x25	0.030	1950	13x35	0.024	2100	16x36	0.025	2550
2200	13x35	0.024	2200	16x32	0.021	2500	18x36	0.025	2800
2700	13x40	0.024	2300	16x36	0.020	2600			
3300	16x32	0.019	2550	16x40	0.019	2800			
3900	16x36	0.019	2650	18x40	0.015	3000			
4700	18x36	0.019	2800	18x40	0.014	3300			

ES

Case size & Permissible Ripple Current

Nominal Capacitance (μ F)	63 V			100 V		
	Case Size ϕ DxL (mm)	Max. Impedance @25°C 100kHz (Ω)	Max. Ripple Current @105°C 100kHz (mA rms)	Case Size ϕ DxL (mm)	Max. Impedance @25°C 100kHz (Ω)	Max. Ripple Current @105°C 100kHz (mA rms)
4.7	5x11	2.5	55	5x11	2.5	65
10	5x11	2.3	110	6.3x11	2.2	115
22	6.3x11	2.1	140	8x12	0.53	305
33	6.3x11	1.2	205	8x16	0.52	400
47	8x12	0.56	305	10x16	0.35	500
68	8x16	0.52	350	10x20	0.19	715
82	8x20	0.48	380	10x20	0.19	735
100	8x20	0.43	420	13x20	0.18	810
150	10x16	0.31	550	13x25	0.14	1005
220	10x20	0.21	580	16x25	0.085	1410
330	13x20	0.16	890	16x32	0.065	1580
470	13x25	0.12	1320	16x36	0.052	1700
560	13x30	0.11	1365	16x40	0.048	1810
680	16x25	0.065	1400	18x36	0.045	1900
820	16x32	0.057	1490	18x40	0.043	2100
1000	16x32	0.054	1620			
1200	16x36	0.047	1790			
1500	18x36	0.040	2000			
2200	18x40	0.038	2150			

LOAD LIFE TEST

————— 470 μ F 35WV
 - - - - - 1200 μ F 25WV

