

## EM

**Feature: Low impedance, high ripple current and miniature with 7 to 9mm height.**

### SPECIFICATIONS

Item	Performance Characteristics										
Category Temperature Range	-40 to +105°C										
Working Voltage Range	6.3 to 35Vdc										
Capacitance Range	33 to 470 $\mu$ F										
Capacitance Tolerance	$\pm 20\%$ (at 25°C 120Hz)										
Dissipation Factor ( $\tan \delta$ ) (at 25°C 120Hz)	<table border="1"> <thead> <tr> <th>Rated Voltage (V)</th> <th>6.3</th> <th>10</th> <th>16</th> <th>25 to 35</th> </tr> </thead> <tbody> <tr> <td><math>\tan \delta</math> (Max)</td> <td>0.24</td> <td>0.20</td> <td>0.16</td> <td>0.14</td> </tr> </tbody> </table>	Rated Voltage (V)	6.3	10	16	25 to 35	$\tan \delta$ (Max)	0.24	0.20	0.16	0.14
Rated Voltage (V)	6.3	10	16	25 to 35							
$\tan \delta$ (Max)	0.24	0.20	0.16	0.14							
Leakage Current	$I = 0.03CV$ or $3 \mu$ A, whichever is greater. I: Leakage current. ( $\mu$ A) C: Rated capacitance. ( $\mu$ F) V: Rated voltage. (V) The rated voltage is impressed for two minutes.										
Endurance	After applying rated voltage to the capacitor for 1,000 hours at 105°C ( $\leq 6.3 \phi$ ) or 2,000 hours at 105°C ( $\geq 8 \phi$ ), the following characteristics shall be satisfied when the capacitor has been restored to 25°C. Capacitance change $\leq \pm 25\%$ of the initial value (6.3V - 10V: $\leq \pm 30\%$ ) Dissipation factor ( $\tan \delta$ ) $\leq 200\%$ of the specified value Leakage current $\leq$ specified value										
Shelf Life	After exposing the capacitor for 500 hours at 105°C, without applying voltage, the following characteristics shall be satisfied when the capacitor has been restored to 25°C. Capacitance change $\leq \pm 25\%$ of the initial value (6.3V - 10V: $\leq \pm 30\%$ ) Dissipation factor ( $\tan \delta$ ) $\leq 200\%$ of the specified value Leakage current $\leq 200\%$ of the specified value										
Others	Conforms to JIS C-5141 (1991), characteristic W										

### RIPPLE CURRENT MULTIPLIERS

#### Temperature Multipliers

Temp (°C)	60	85	105
Factor	1.40	1.15	1.00

#### Frequency Multipliers

Freq. (Hz)	120	1K	10K	100K $\leq$ 200K
Cap. ( $\mu$ F)				
33 to 82	0.50	0.80	0.98	1.00
100 to 470	0.55	0.85	0.95	1.00

#### DIMENSIONS (mm)

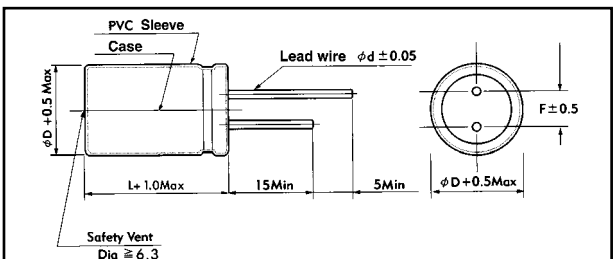

$\phi$ D	4	5	6.3	8
d	0.45	0.45	0.45	0.45
F	1.5	2.0	2.5	3.5

**EM**

**Case size & Permissible Ripple Current**

Nominal Capacitance ( $\mu F$ )	6.3 V			10 V			16 V		
	Case Size	Max. Impedance @25°C 100kHz ( $\Omega$ )	Max. Ripple Current @105°C 100kHz (mA rms)	Case Size	Max. Impedance @25°C 100kHz ( $\Omega$ )	Max. Ripple Current @105°C 100kHz (mA rms)	Case Size	Max. Impedance @25°C 100kHz ( $\Omega$ )	Max. Ripple Current @105°C 100kHz (mA rms)
	$\phi$ DxL (mm)			$\phi$ DxL (mm)			$\phi$ DxL (mm)		
100							8x7	0.24	330
150	8x7	0.23	305	8x7	0.21	315	8x7	0.15	385
220	8x7	0.15	380	8x7	0.14	390	8x7	0.13	405
330	8x7	0.14	405	8x9	0.13	465	8x9	0.12	505
470	8x9	0.13	465	8x9	0.12	480	8x9	0.11	535

Nominal Capacitance ( $\mu F$ )	25 V			30 V			35 V		
	Case Size	Max. Impedance @25°C 100kHz ( $\Omega$ )	Max. Ripple Current @105°C 100kHz (mA rms)	Case Size	Max. Impedance @25°C 100kHz ( $\Omega$ )	Max. Ripple Current @105°C 100kHz (mA rms)	Case Size	Max. Impedance @25°C 100kHz ( $\Omega$ )	Max. Ripple Current @105°C 100kHz (mA rms)
	$\phi$ DxL (mm)			$\phi$ DxL (mm)			$\phi$ DxL (mm)		
33	8x7	0.36	215				8x7	0.30	250
47	8x7	0.28	250				8x7	0.23	310
56	8x7	0.23	310				8x7	0.16	380
68	8x7	0.19	330				8x7	0.15	400
100	8x7	0.15	380				8x7	0.14	420
150	8x7	0.14	465	8x7	0.13	680	8x9	0.12	700
180	8x9	0.12	760	8x9	0.11	765			
220	8x9	0.10	800						

**LOAD LIFE TEST**

———— 100uF/25V  
 - - - - - 150uF/25V

